

Intro Lecture:

Computer History & Theory

Nathan Hull

Analog Clock



Local time

Digital Clock



Local time

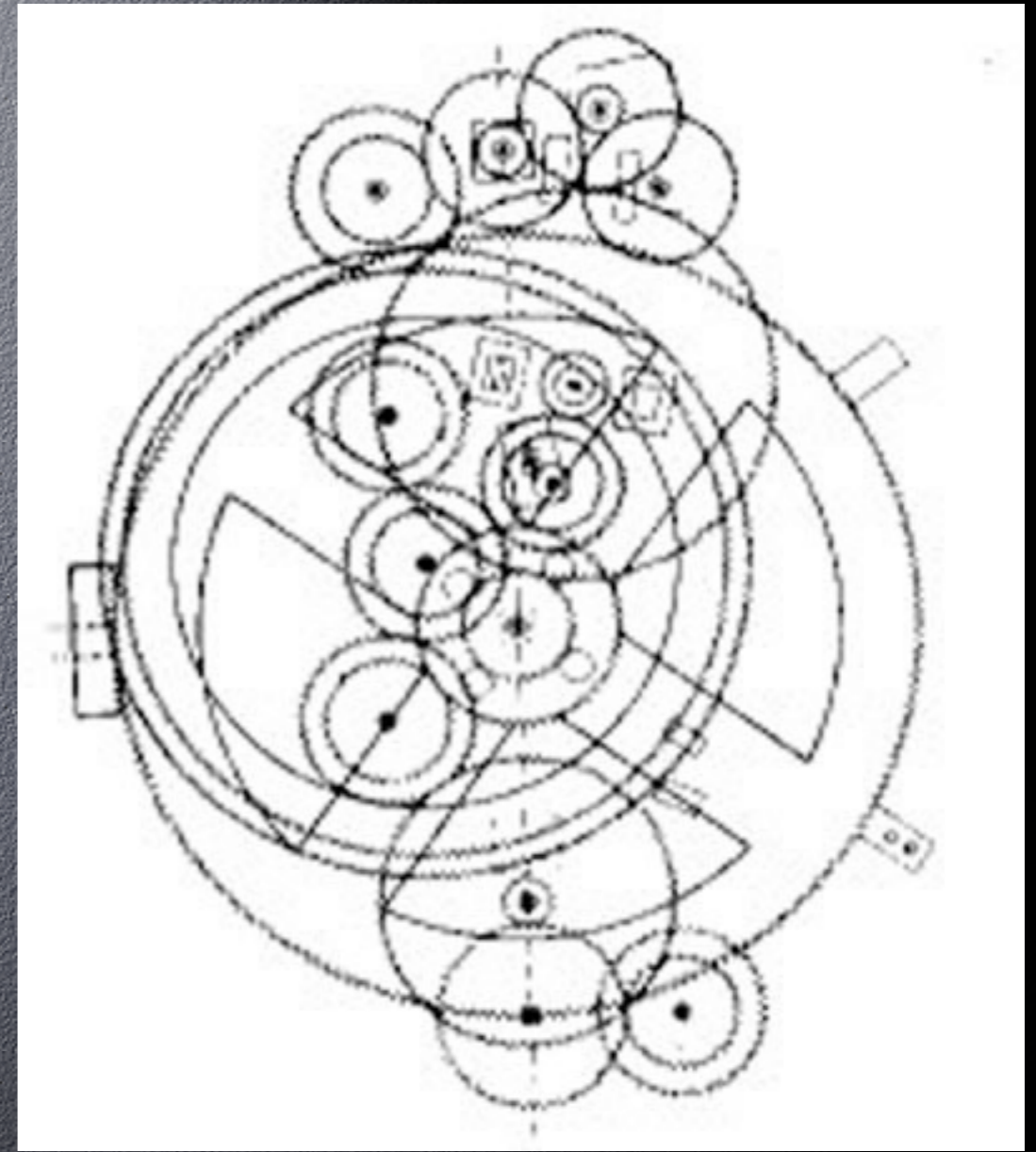

The Antikythera Mechanism



John Napier
1550 - 1617

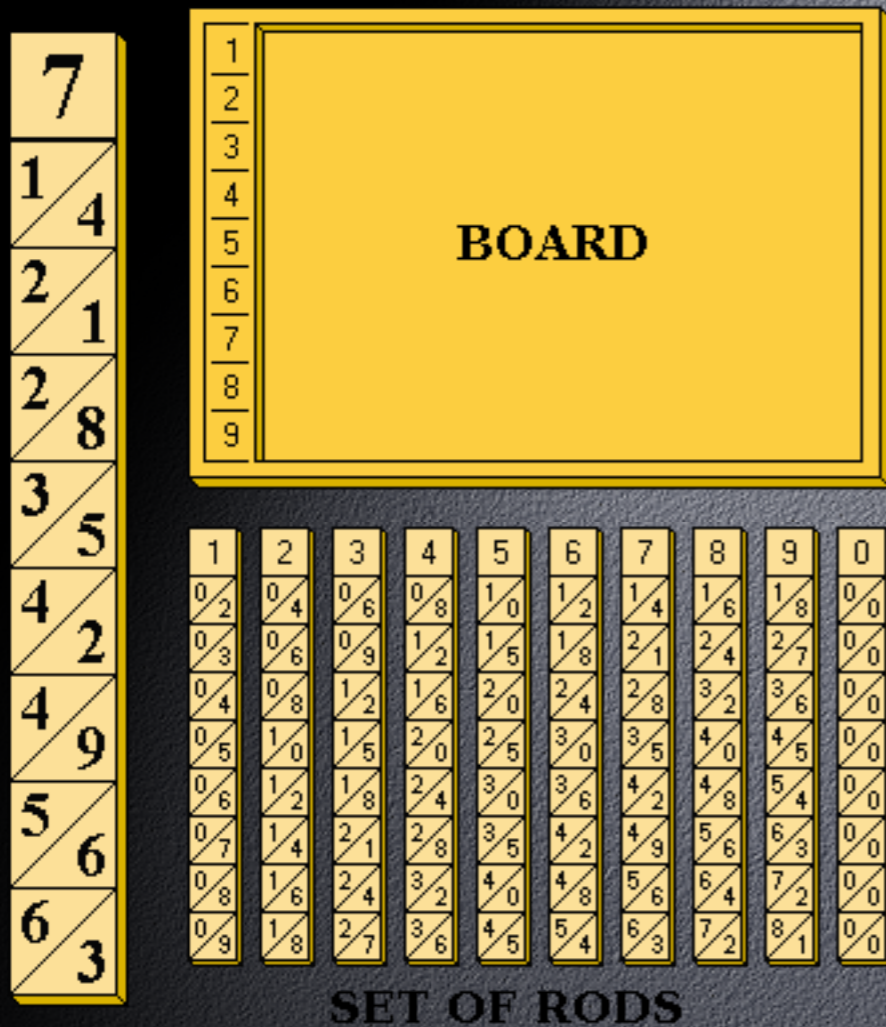

Napier's Bones

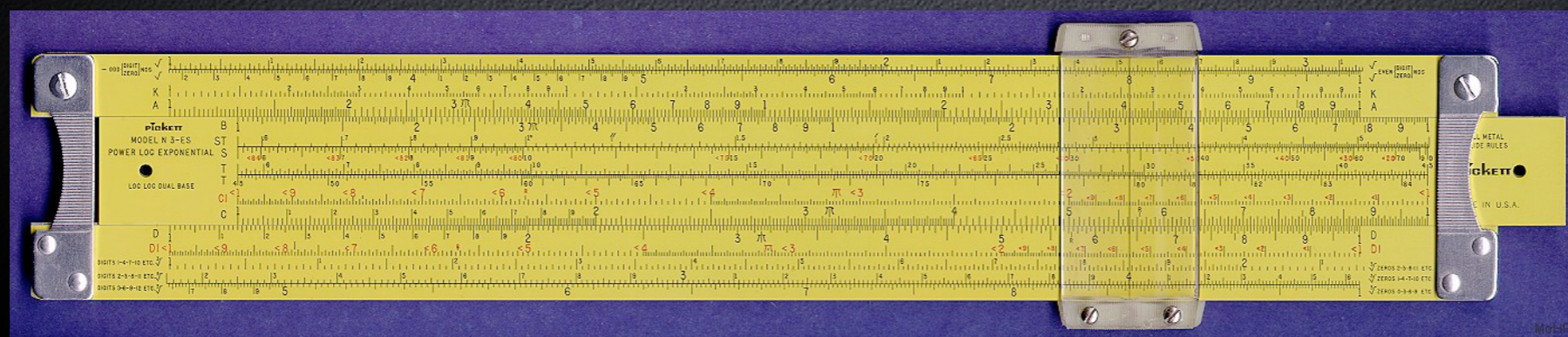



Blaise Pascal
1623-1662



Pascaline

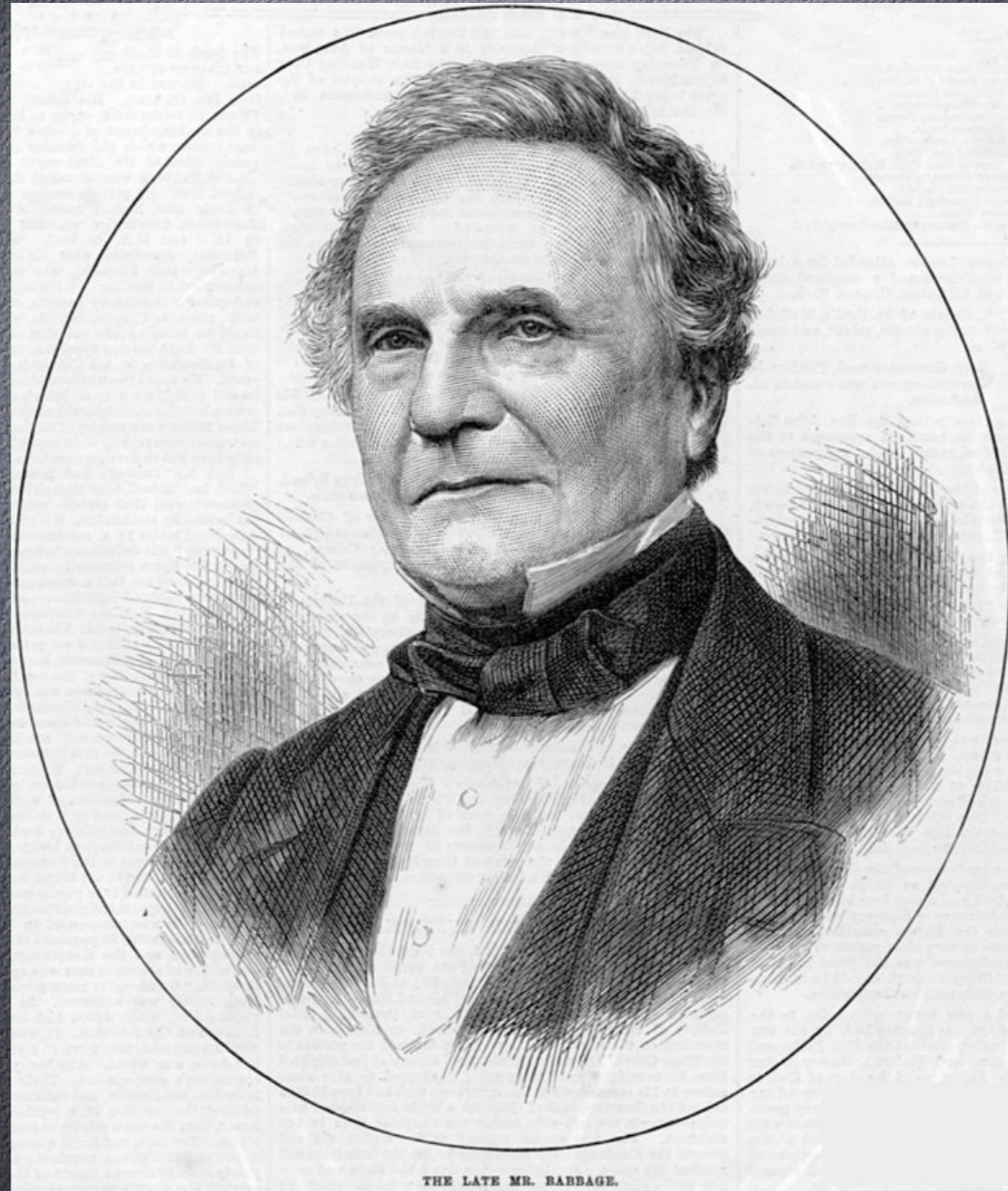

Charles Babbage
1791-1871

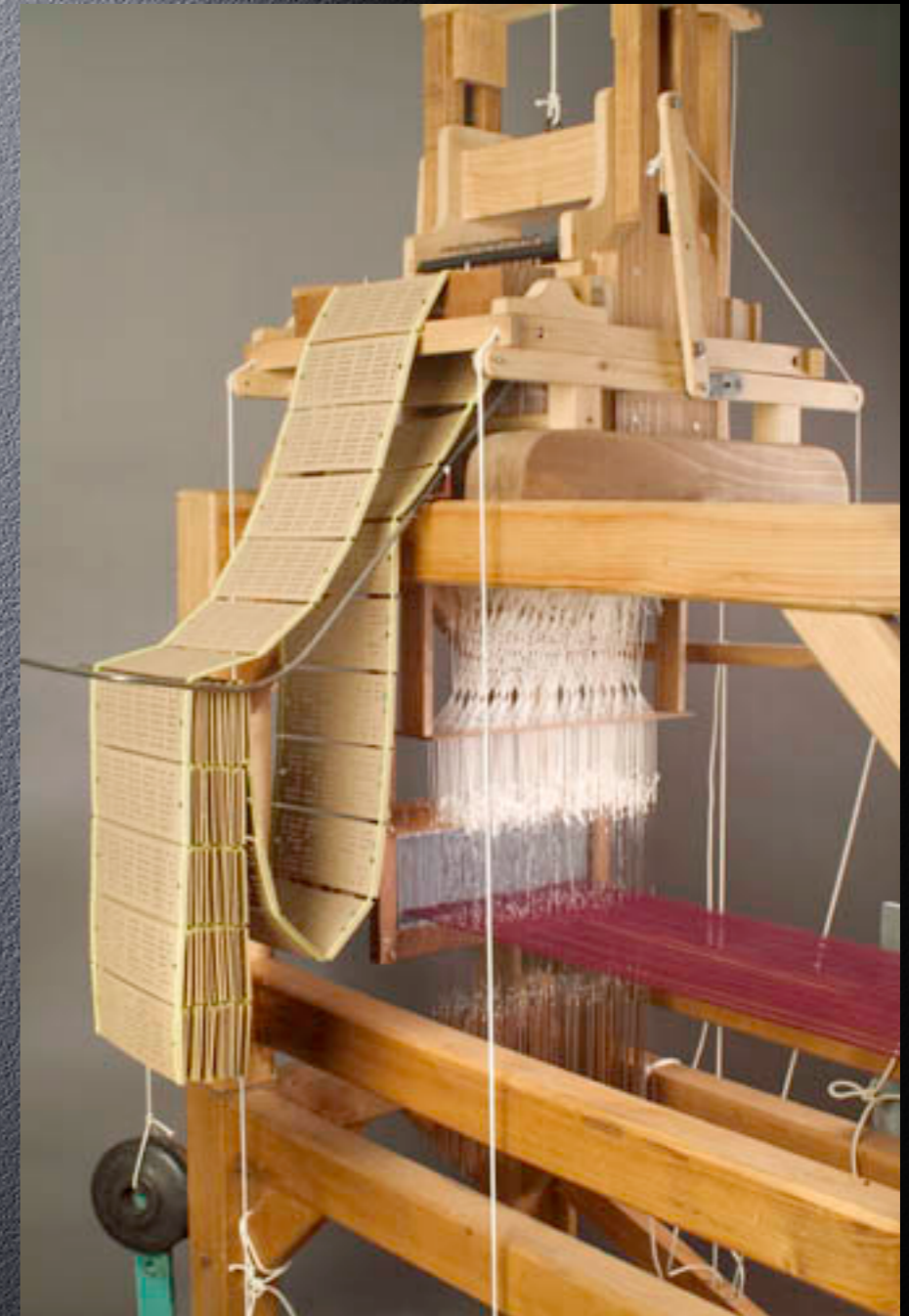
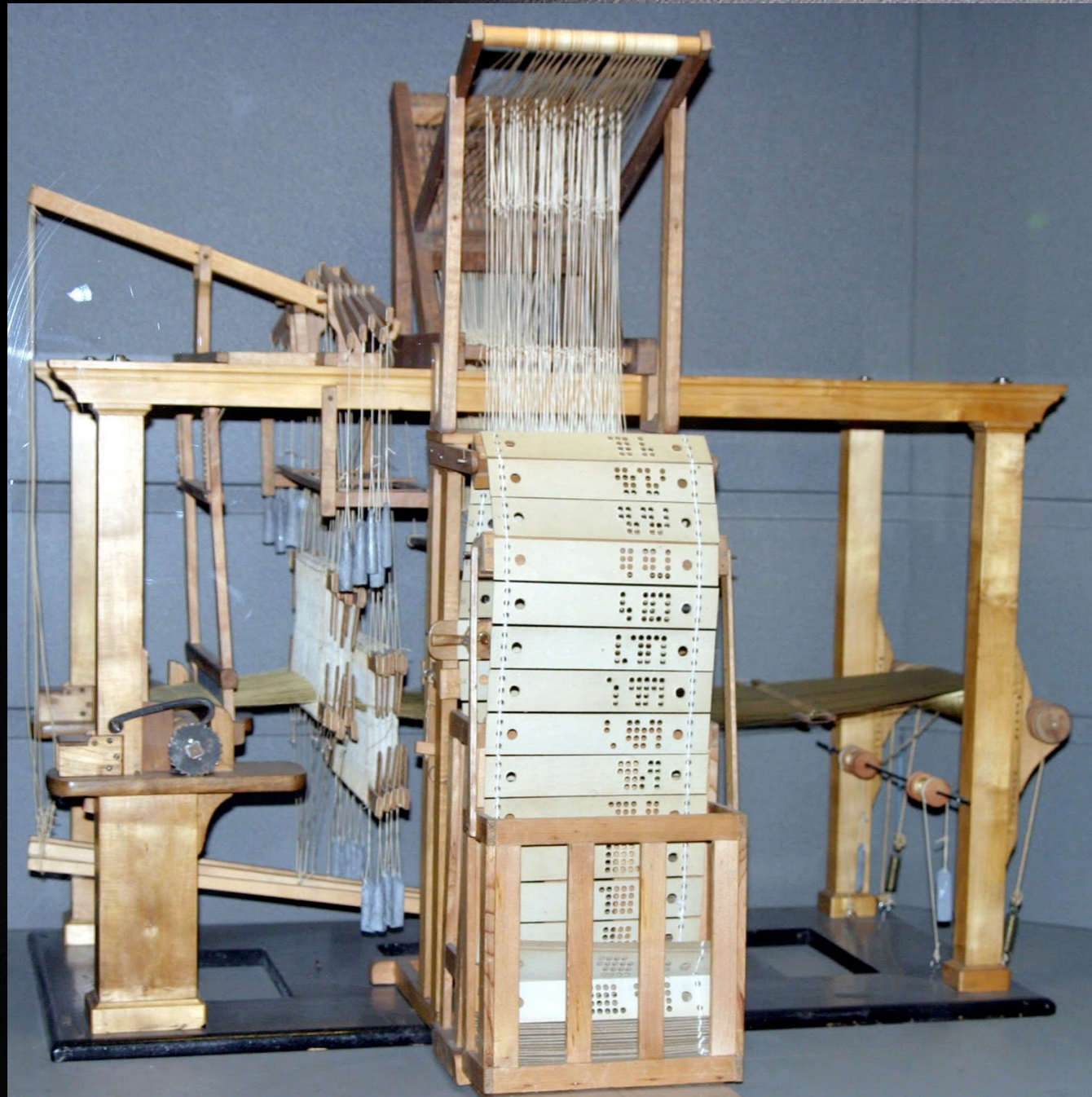

Jacquard Loom

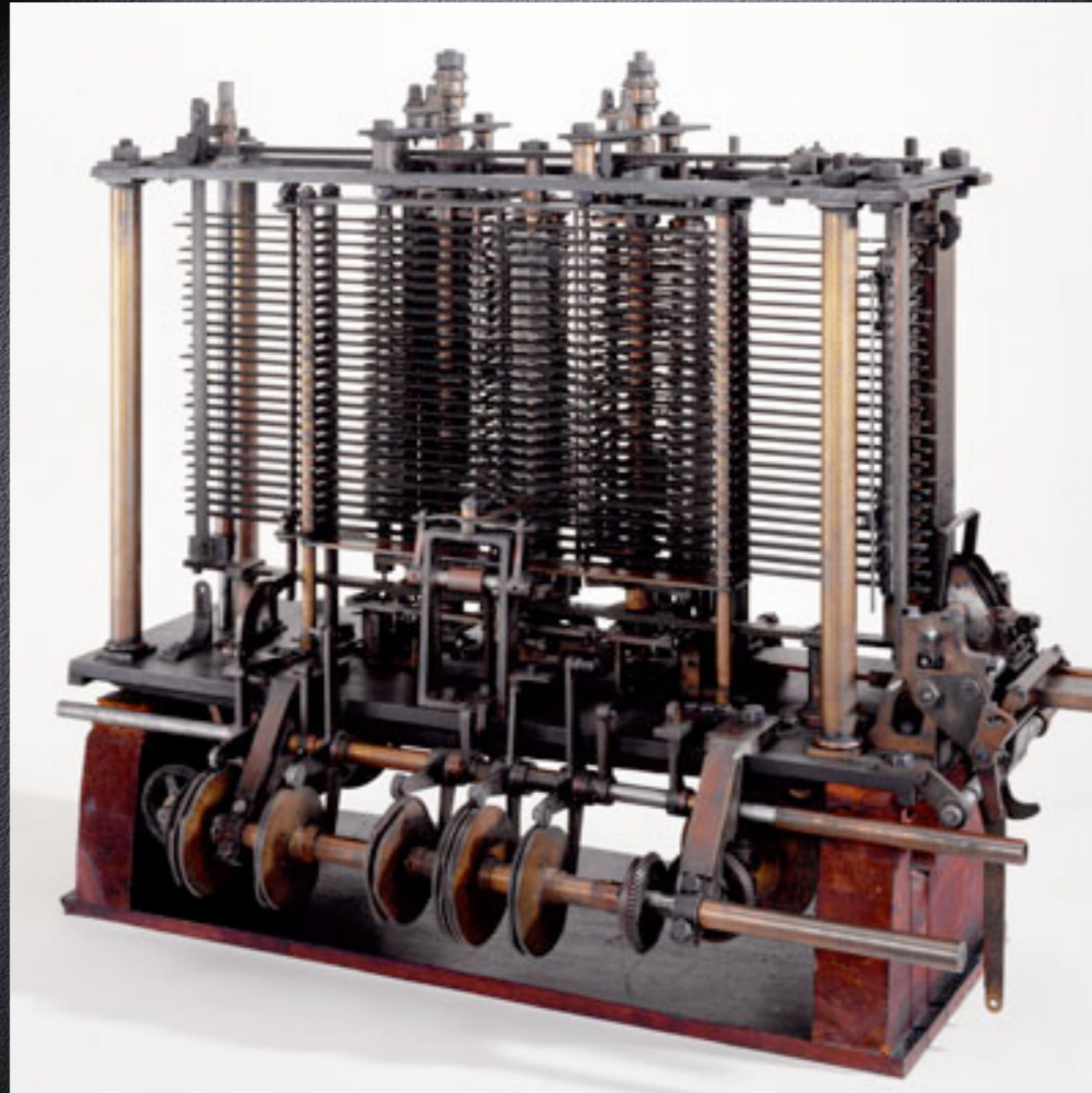

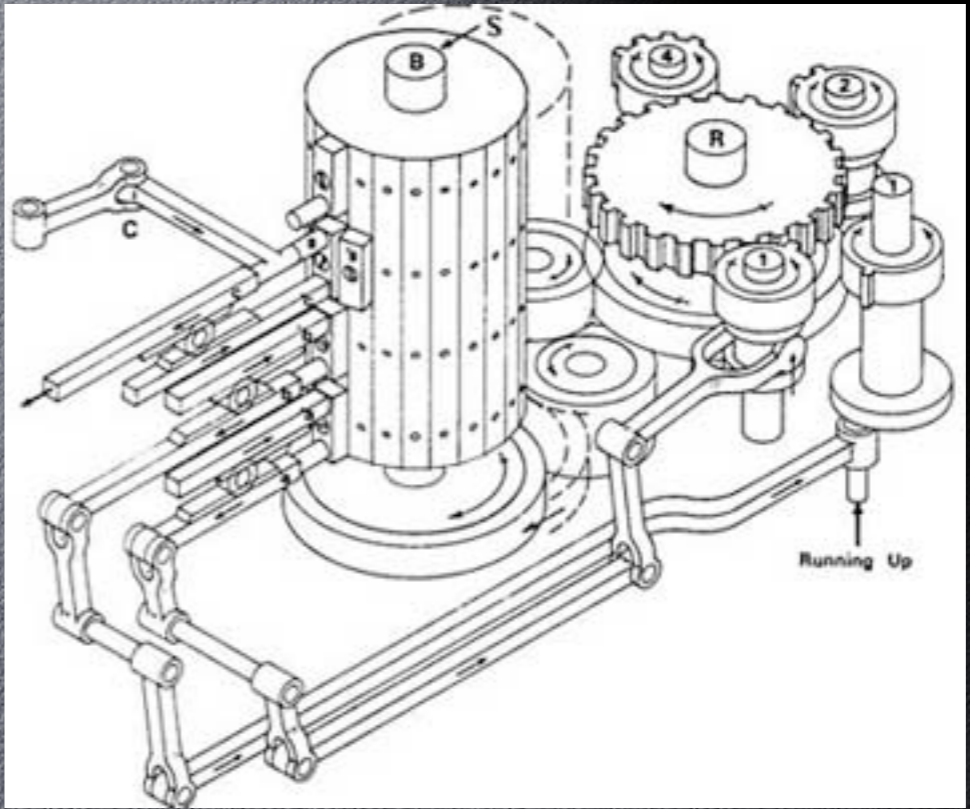



Ada Lovelace

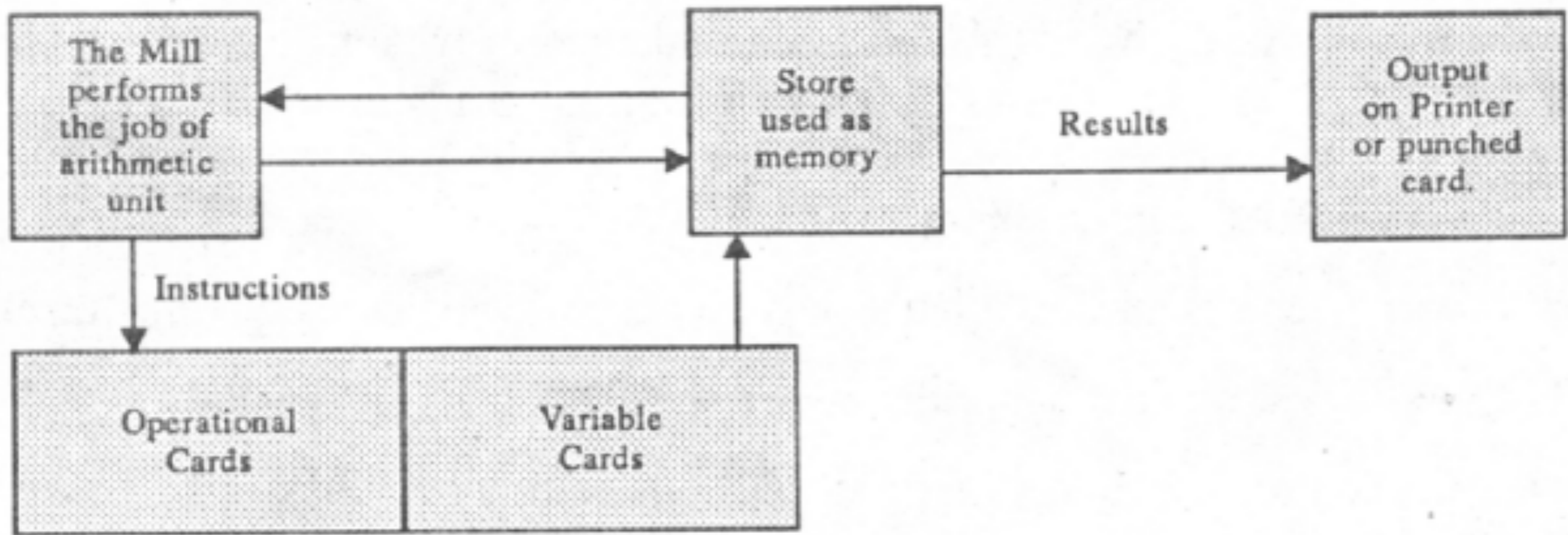

Cards make the program
Each card contains an
instruction.

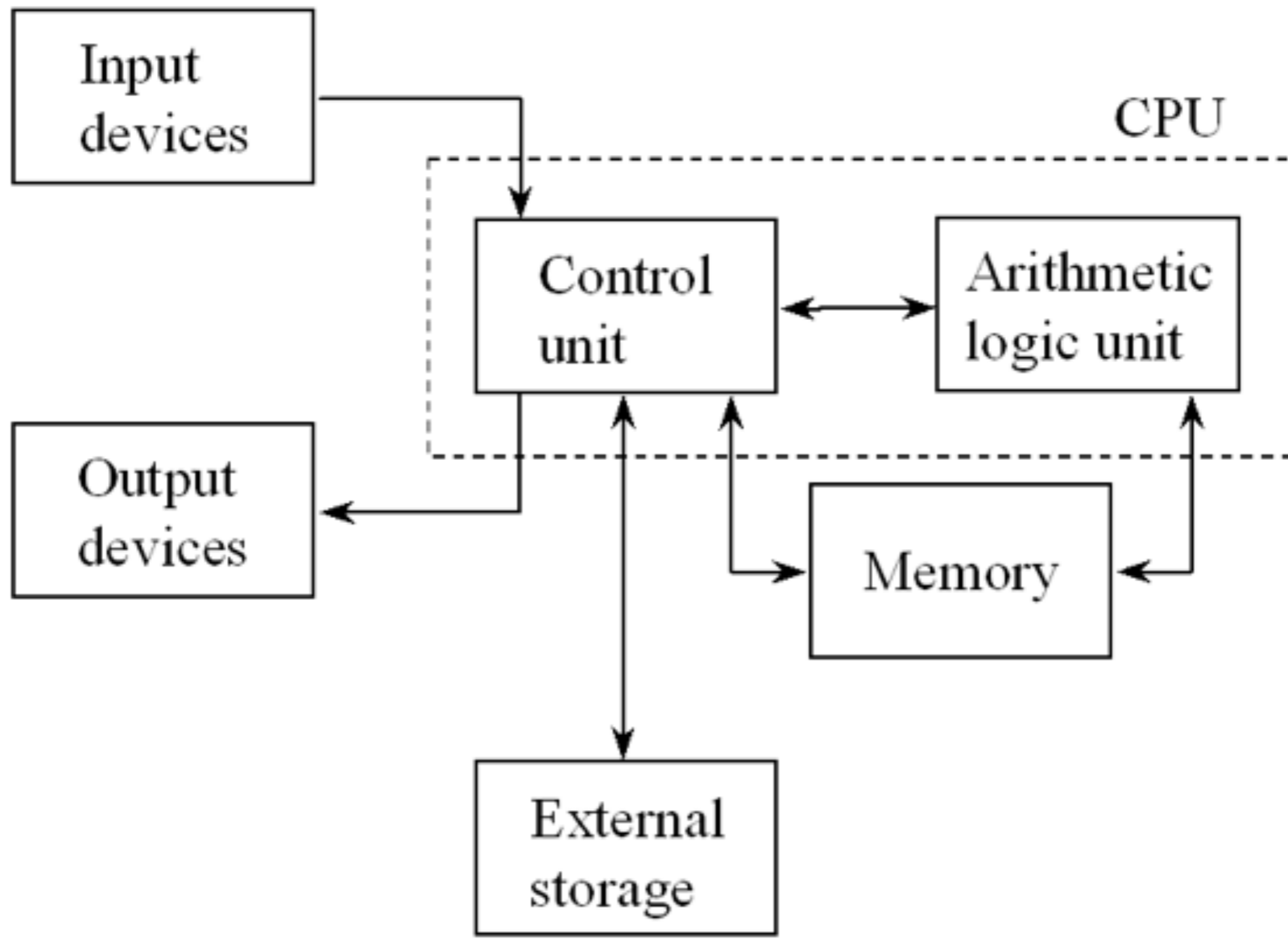

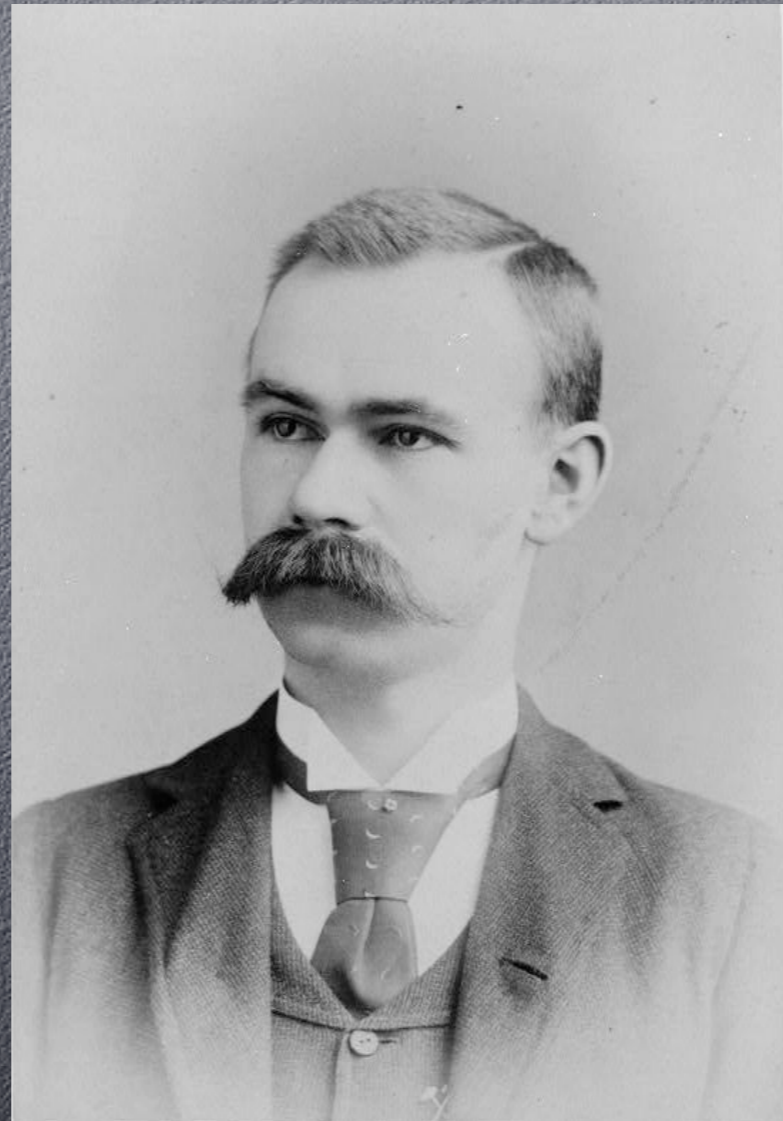

Herman Hollerith

1860 - 1929

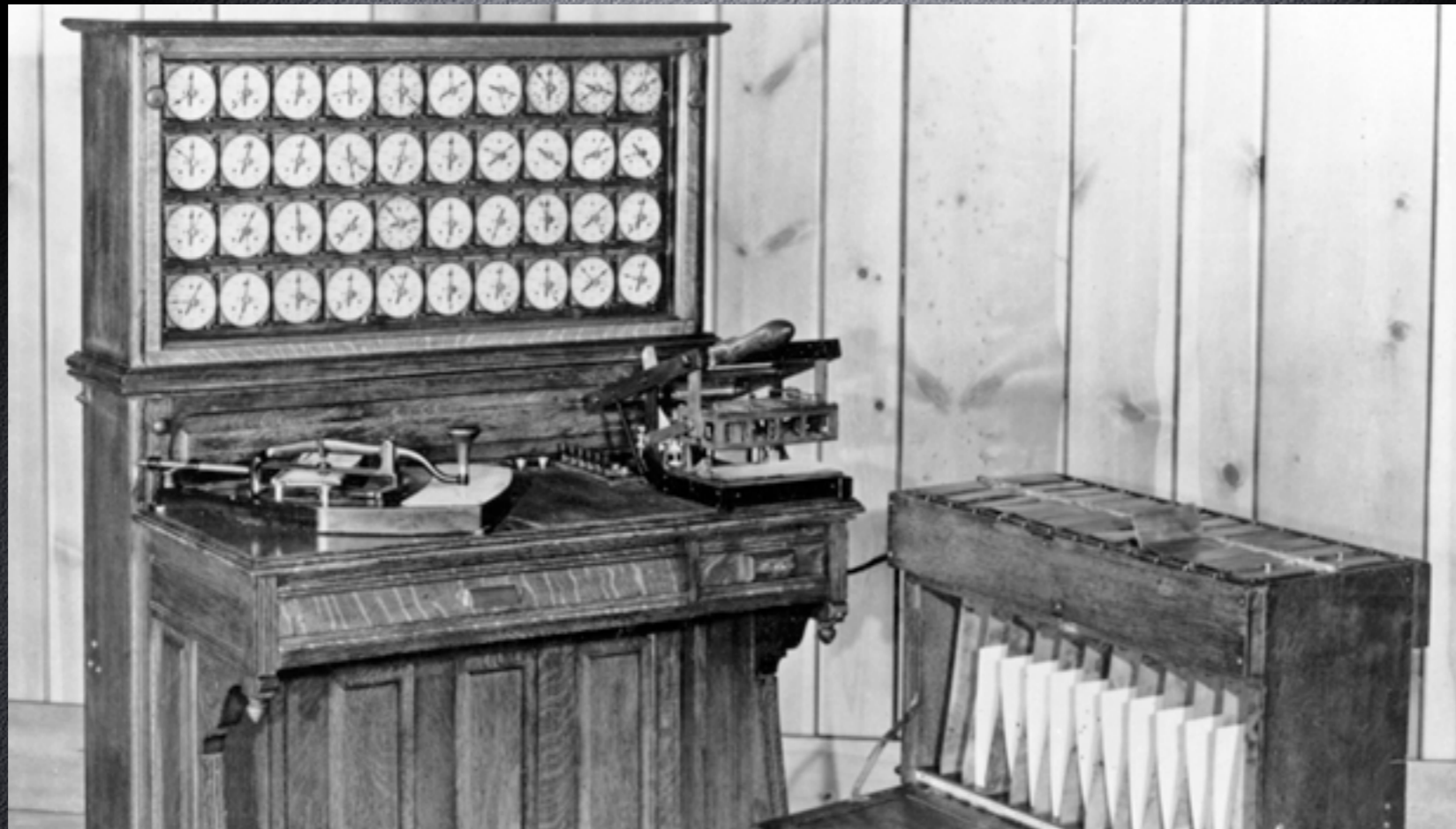

Tabulating Machine
1890 Census

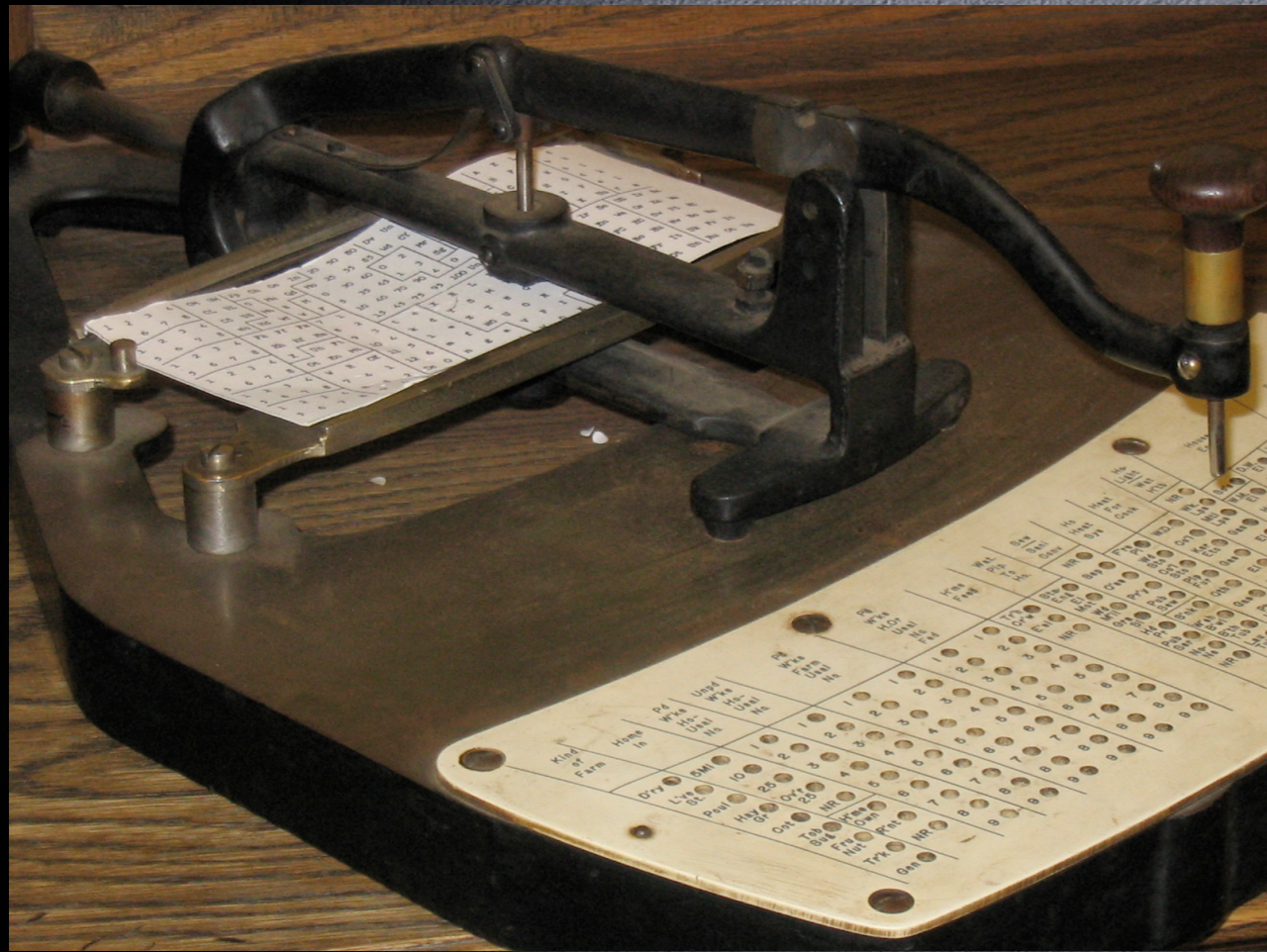

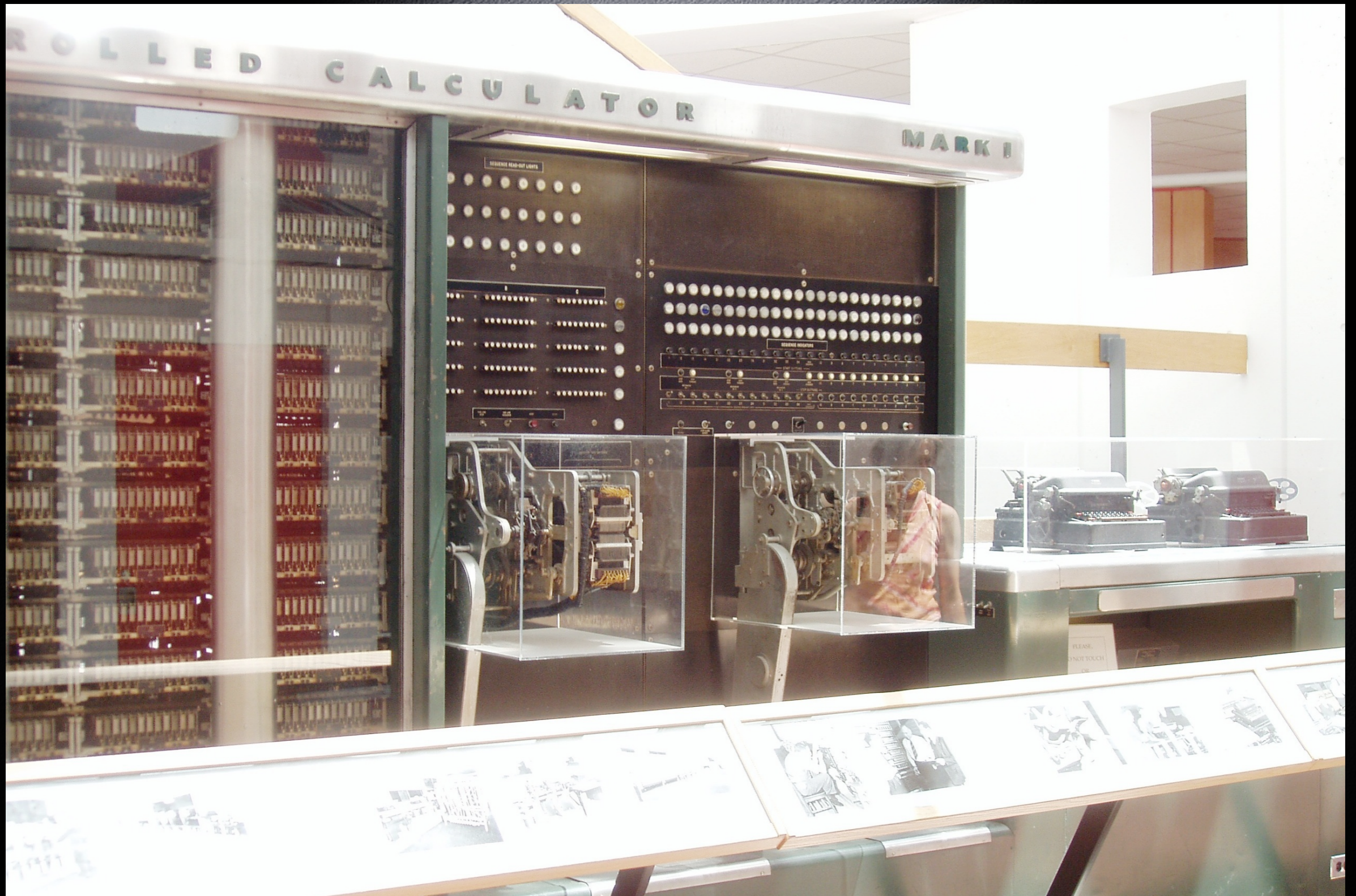

Mark I Computer



REAR ADMIRAL
GRACE HOPPER

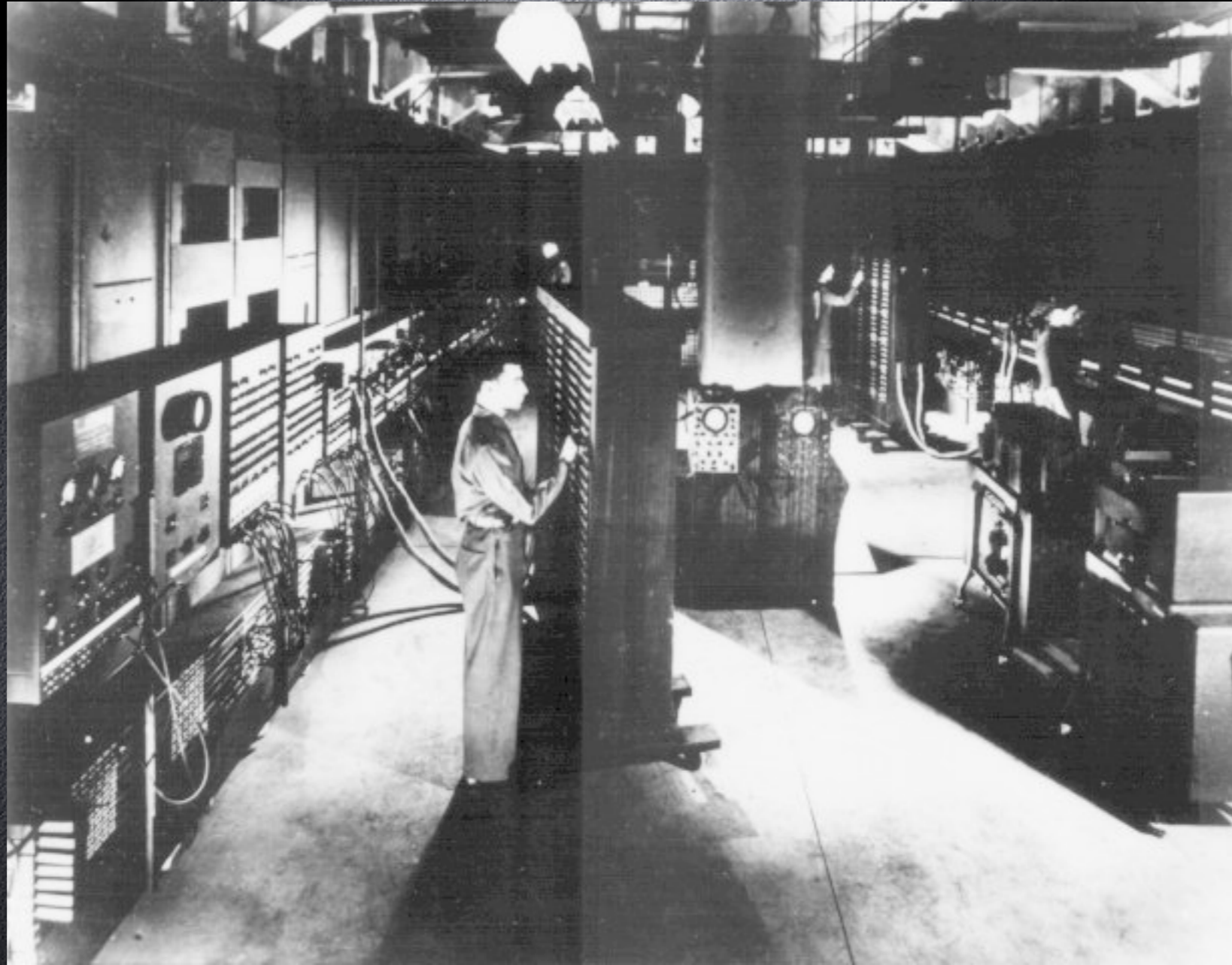

Eniac Computer - 1945



John Presper Eckert and John Mauchly

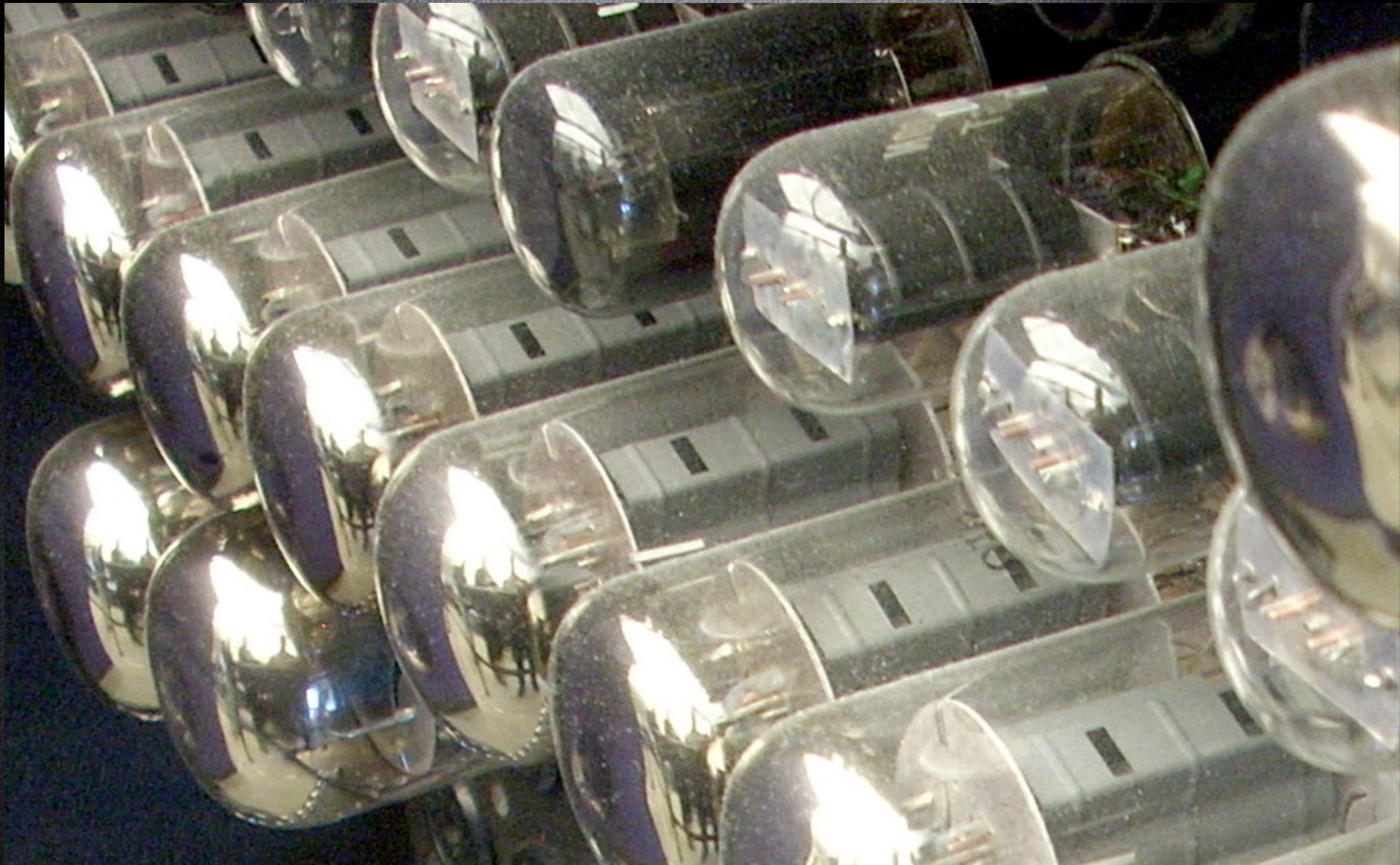

Eniac Vacuum Tubes

Dec	Hex	Oct	Binaire	Dec	Hex	Oct	Binaire	Dec	Hex	Oct	Binaire	Dec	Hex	Oct	Binaire
0	0	000	00000000	16	10	020	00010000	32	20	040	00100000	48	30	060	00110000
1	1	001	00000001	17	11	021	00010001	33	21	041	00100001	49	31	061	00110001
2	2	002	00000010	18	12	022	00010010	34	22	042	00100010	50	32	062	00110010
3	3	003	00000011	19	13	023	00010011	35	23	043	00100011	51	33	063	00110011
4	4	004	00000100	20	14	024	00010100	36	24	044	00100100	52	34	064	00110100
5	5	005	00000101	21	15	025	00010101	37	25	045	00100101	53	35	065	00110101
6	6	006	00000110	22	16	026	00010110	38	26	046	00100110	54	36	066	00110110
7	7	007	00000111	23	17	027	00010111	39	27	047	00100111	55	37	067	00110111
8	8	010	00001000	24	18	030	00011000	40	28	050	00101000	56	38	070	00111000
9	9	011	00001001	25	19	031	00011001	41	29	051	00101001	57	39	071	00111001
10	A	012	00001010	26	1A	032	00011010	42	2A	052	00101010	58	3A	072	00111010
11	B	013	00001011	27	1B	033	00011011	43	2B	053	00101011	59	3B	073	00111011
12	C	014	00001100	28	1C	034	00011100	44	2C	054	00101100	60	3C	074	00111100
13	D	015	00001101	29	1D	035	00011101	45	2D	055	00101101	61	3D	075	00111101
14	E	016	00001110	30	1E	036	00011110	46	2E	056	00101110	62	3E	076	00111110
15	F	017	00001111	31	1F	037	00011111	47	2F	057	00101111	63	3F	077	00111111
Dec	Hex	Oct	Binaire	Dec	Hex	Oct	Binaire	Dec	Hex	Oct	Binaire	Dec	Hex	Oct	Binaire
64	40	100	01000000	80	50	120	01010000	96	60	140	01100000	112	70	160	01110000
65	41	101	01000001	81	51	121	01010001	97	61	141	01100001	113	71	161	01110001
66	42	102	01000010	82	52	122	01010010	98	62	142	01100010	114	72	162	01110010
67	43	103	01000011	83	53	123	01010011	99	63	143	01100011	115	73	163	01110011
68	44	104	01000100	84	54	124	01010100	100	64	144	01100100	116	74	164	01110100
69	45	105	01000101	85	55	125	01010101	101	65	145	01100101	117	75	165	01110101
70	46	106	01000110	86	56	126	01010110	102	66	146	01100110	118	76	166	01110110
71	47	107	01000111	87	57	127	01010111	103	67	147	01100111	119	77	167	01110111
72	48	110	01001000	88	58	130	01011000	104	68	150	01101000	120	78	170	01111000
73	49	111	01001001	89	59	131	01011001	105	69	151	01101001	121	79	171	01111001
74	4A	112	01001010	90	5A	132	01011010	106	6A	152	01101010	122	7A	172	01111010
75	4B	113	01001011	91	5B	133	01011011	107	6B	153	01101011	123	7B	173	01111011
76	4C	114	01001100	92	5C	134	01011100	108	6C	154	01101100	124	7C	174	01111100
77	4D	115	01001101	93	5D	135	01011101	109	6D	155	01101101	125	7D	175	01111101
78	4E	116	01001110	94	5E	136	01011110	110	6E	156	01101110	126	7E	176	01111110
79	4F	117	01001111	95	5F	137	01011111	111	6F	157	01101111	127	7F	177	01111111

Bit positions:

8

7

6

5

4

3

2

1

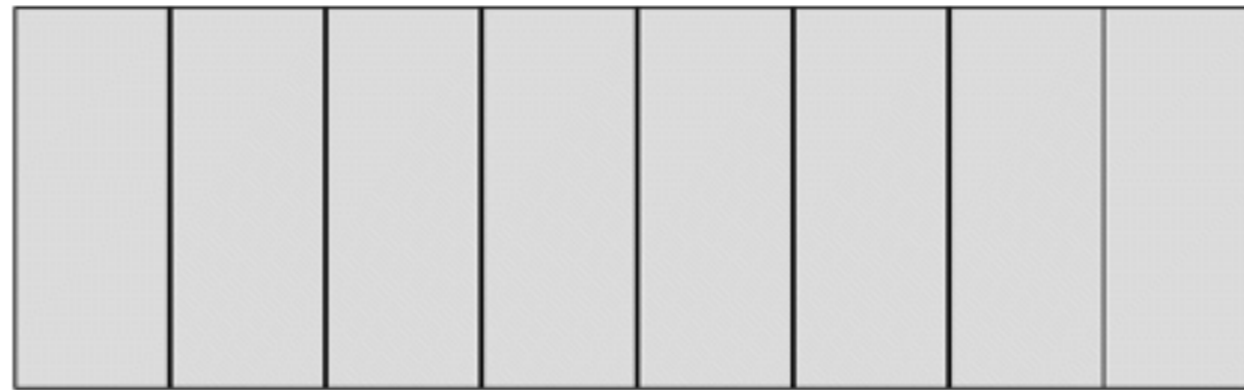

$2^0 = 1$

$2^1 = 2$

$2^2 = 4$

$2^3 = 8$

$2^4 = 16$

$2^5 = 32$

$2^6 = 64$

$2^7 = 128$

A + B	SUM	CARRY
0 + 0	0	0
0 + 1	1	0
1 + 0	1	0
1 + 1	0	1

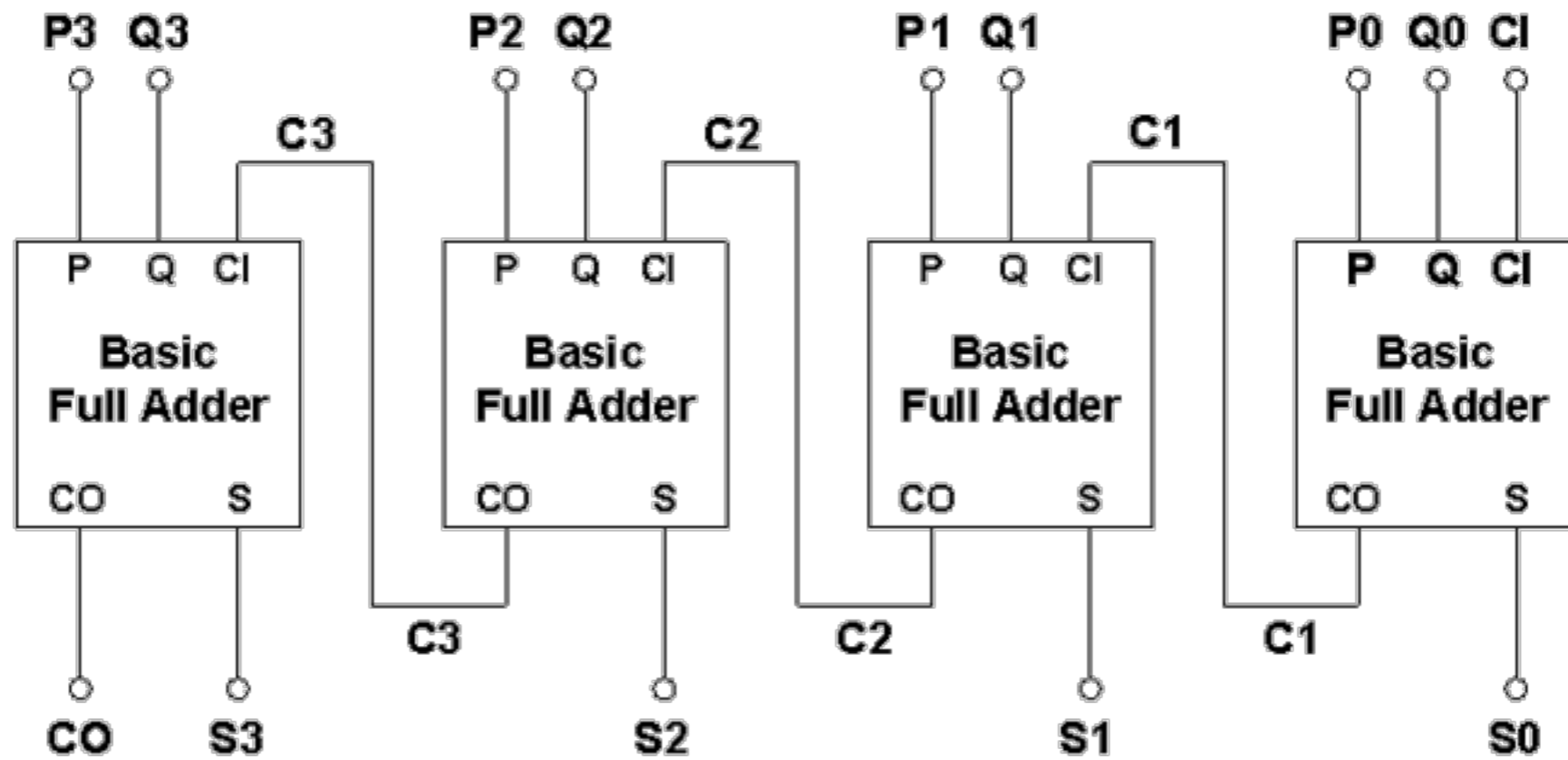

Binary Adders

Binary:	0	1	1	0	0	1	0	1
Decimal:	128	64	32	16	8	4	2	1
	No	Yes	Yes	No	No	Yes	No	Yes
		64 + 32			+	4	+	1
↓								
Decimal Equivalent: 101								

Binary to Decimal Conversion

⁴	³	²	¹	⁰
16	16	16	16	16
65,536	4,096	256	16	1
		E	A	D

Hexadecimal - Powers of 16

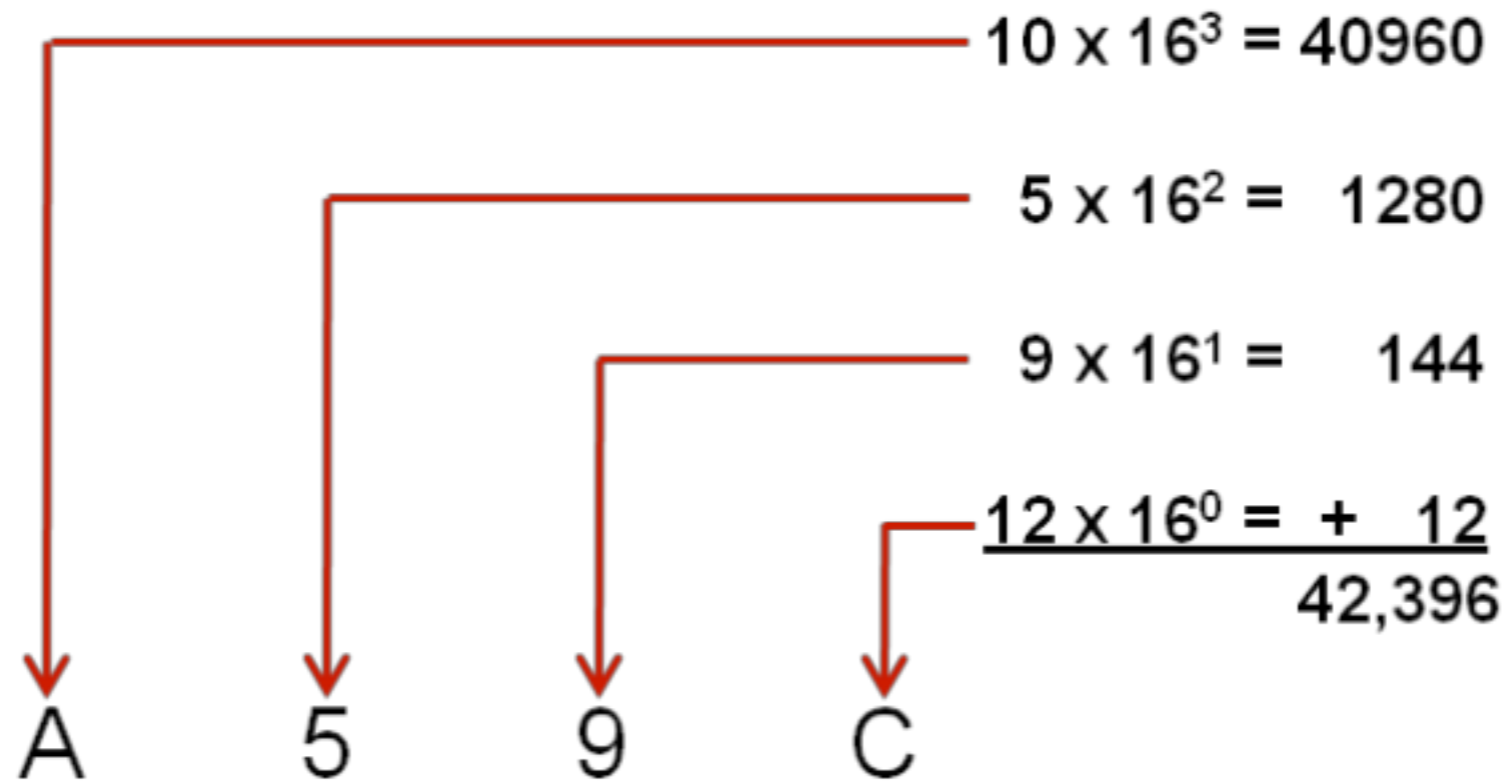

Hexadecimal to Decimal Conversion

Binary	Hex	Decimal
0000	0	0
0001	1	1
0010	2	2
0011	3	3
0100	4	4
0101	5	5
0110	6	6
0111	7	7
1000	8	8
1001	9	9
1010	10	A
1011	11	B
1100	12	C
1101	13	D
1110	14	E
1111	15	F

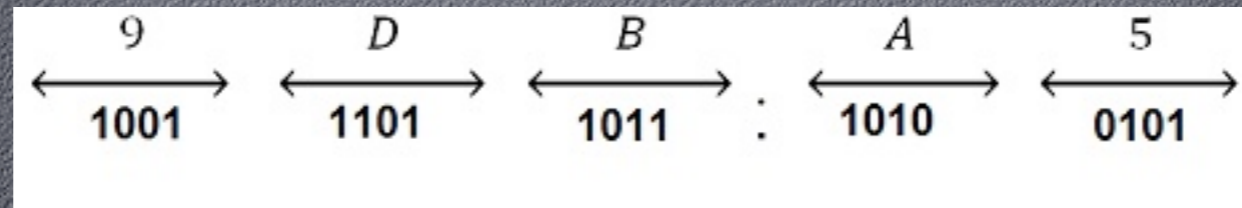

Binary to Hexadecimal

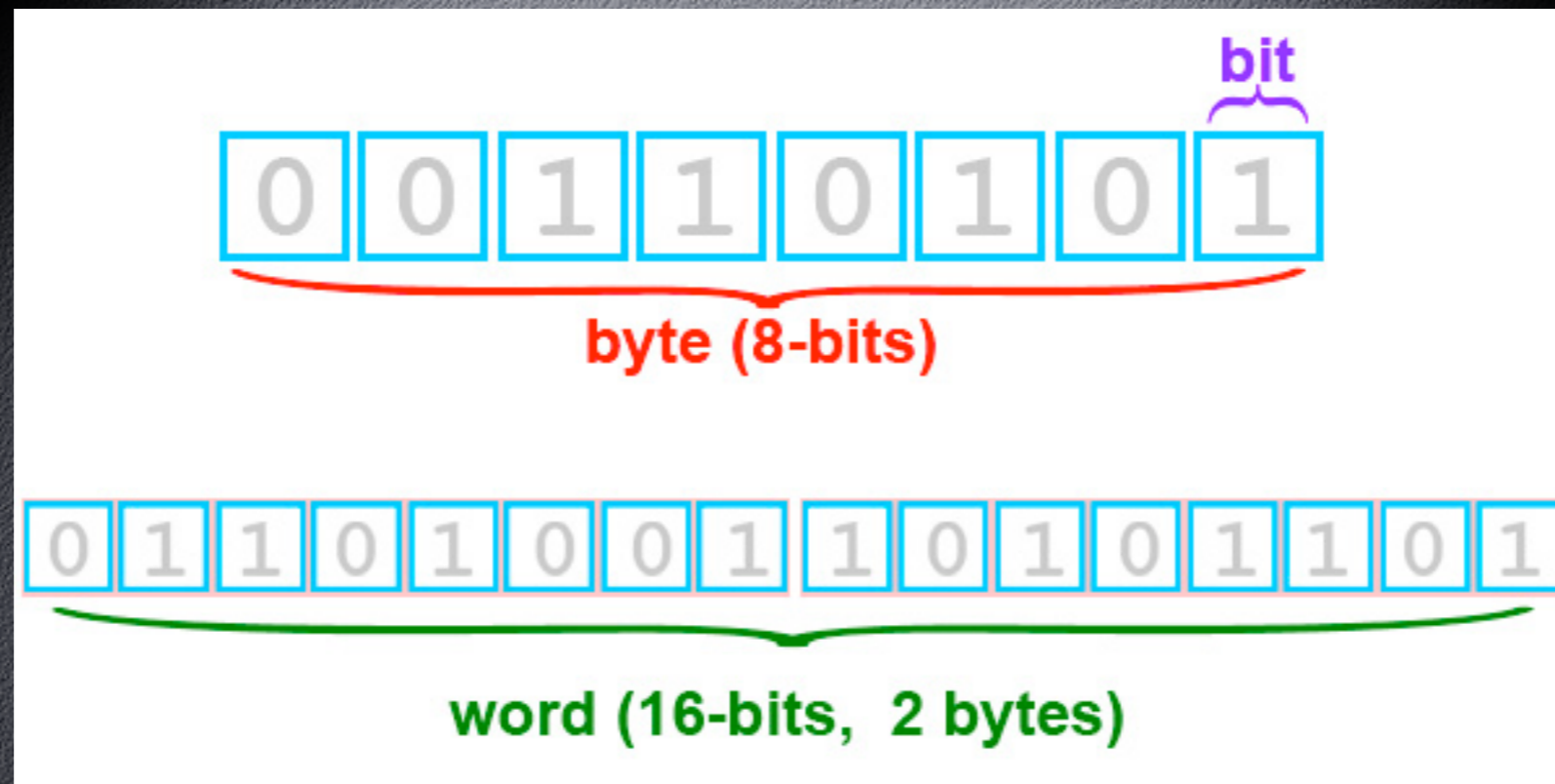

1 Byte = 8 Bits

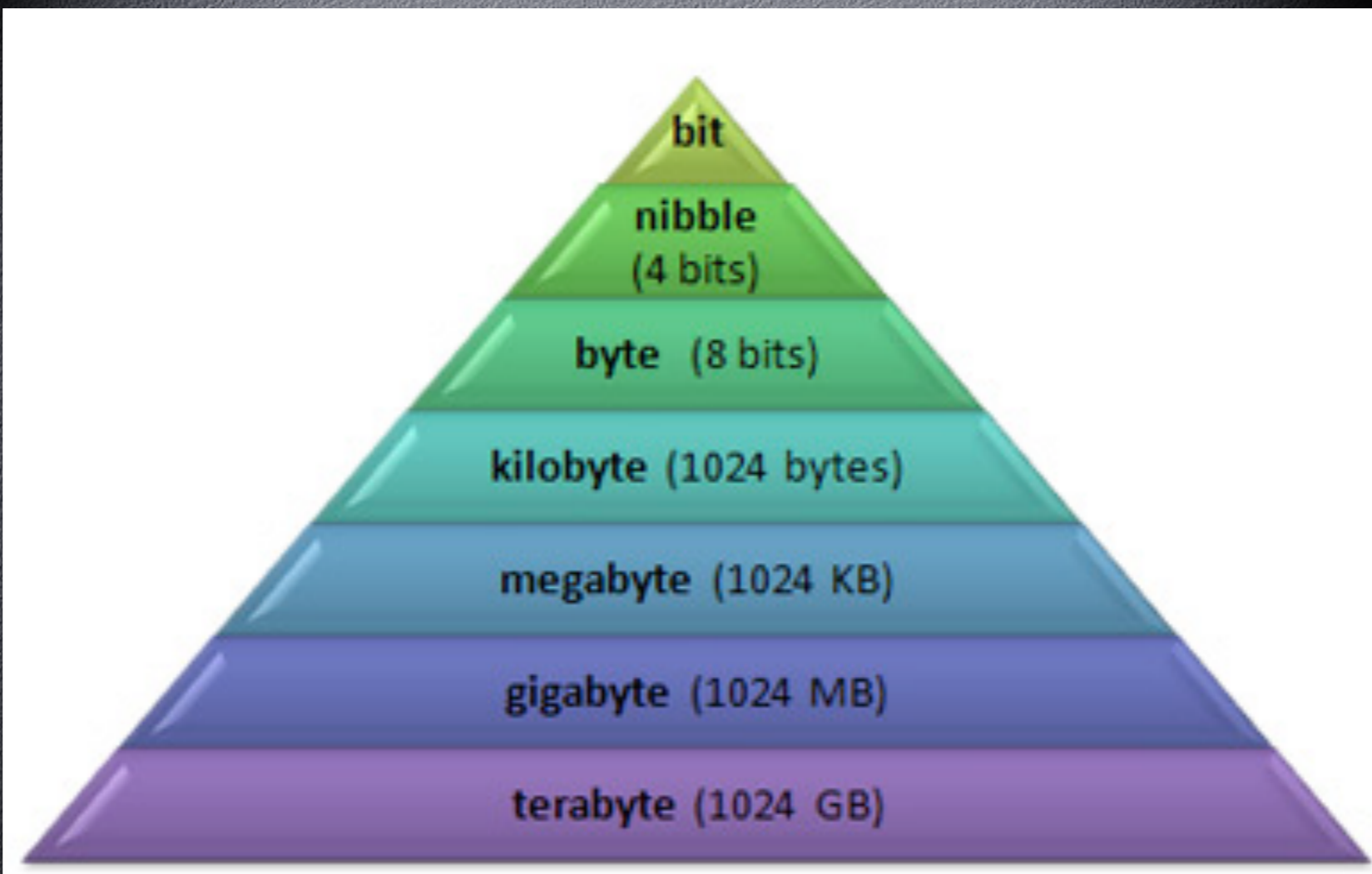

Memory Sizes

kilobyte	KB	2^{10}	1.024	=
megabyte	MB	2^{20}	1.048.576	1.024KB
gigabyte	GB	2^{30}	1.073.741.824	1.024MB
terabyte	TB	2^{40}	1.099.511.627.776	1.024GB
petabyte	PB	2^{50}	1.125.899.906.842.624	1.024TB
exabyte	EB	2^{60}	1.152.921.504.606.846.976	1.024PB
zettabyte	ZB	2^{70}	1.180.591.620.717.411.303.424	1.024EB
yottabyte	YB	2^{80}	1.208.925.819.614.629.174.706.176	1.024ZB

ASCII TABLE

Decimal	Hex	Char	Decimal	Hex	Char	Decimal	Hex	Char	Decimal	Hex	Char
0	0	[NULL]	32	20	[SPACE]	64	40	@	96	60	`
1	1	[START OF HEADING]	33	21	!	65	41	A	97	61	a
2	2	[START OF TEXT]	34	22	"	66	42	B	98	62	b
3	3	[END OF TEXT]	35	23	#	67	43	C	99	63	c
4	4	[END OF TRANSMISSION]	36	24	\$	68	44	D	100	64	d
5	5	[ENQUIRY]	37	25	%	69	45	E	101	65	e
6	6	[ACKNOWLEDGE]	38	26	&	70	46	F	102	66	f
7	7	[BELL]	39	27	'	71	47	G	103	67	g
8	8	[BACKSPACE]	40	28	(72	48	H	104	68	h
9	9	[HORIZONTAL TAB]	41	29)	73	49	I	105	69	i
10	A	[LINE FEED]	42	2A	*	74	4A	J	106	6A	j
11	B	[VERTICAL TAB]	43	2B	+	75	4B	K	107	6B	k
12	C	[FORM FEED]	44	2C	,	76	4C	L	108	6C	l
13	D	[CARRIAGE RETURN]	45	2D	-	77	4D	M	109	6D	m
14	E	[SHIFT OUT]	46	2E	.	78	4E	N	110	6E	n
15	F	[SHIFT IN]	47	2F	/	79	4F	O	111	6F	o
16	10	[DATA LINK ESCAPE]	48	30	0	80	50	P	112	70	p
17	11	[DEVICE CONTROL 1]	49	31	1	81	51	Q	113	71	q
18	12	[DEVICE CONTROL 2]	50	32	2	82	52	R	114	72	r
19	13	[DEVICE CONTROL 3]	51	33	3	83	53	S	115	73	s
20	14	[DEVICE CONTROL 4]	52	34	4	84	54	T	116	74	t
21	15	[NEGATIVE ACKNOWLEDGE]	53	35	5	85	55	U	117	75	u
22	16	[SYNCHRONOUS IDLE]	54	36	6	86	56	V	118	76	v
23	17	[ENG OF TRANS. BLOCK]	55	37	7	87	57	W	119	77	w
24	18	[CANCEL]	56	38	8	88	58	X	120	78	x
25	19	[END OF MEDIUM]	57	39	9	89	59	Y	121	79	y
26	1A	[SUBSTITUTE]	58	3A	:	90	5A	Z	122	7A	z
27	1B	[ESCAPE]	59	3B	;	91	5B	[123	7B	{
28	1C	[FILE SEPARATOR]	60	3C	<	92	5C	\	124	7C	
29	1D	[GROUP SEPARATOR]	61	3D	=	93	5D]	125	7D	}
30	1E	[RECORD SEPARATOR]	62	3E	>	94	5E	^	126	7E	~
31	1F	[UNIT SEPARATOR]	63	3F	?	95	5F	_	127	7F	[DEL]

128	Ç	144	É	160	á	176	☐	192	⌞	208	⌞	224	α	240	≡
129	ü	145	æ	161	í	177	☐	193	⌞	209	⌞	225	β	241	±
130	é	146	Æ	162	ó	178	☐	194	⌞	210	⌞	226	Γ	242	≥
131	â	147	ô	163	ú	179		195	⌞	211	⌞	227	π	243	≤
132	ä	148	ö	164	ñ	180	⌞	196	—	212	⌞	228	Σ	244	∫
133	à	149	ò	165	Ñ	181	⌞	197	⌞	213	⌞	229	σ	245	∫
134	â	150	û	166	ª	182	⌞	198	⌞	214	⌞	230	μ	246	÷
135	ç	151	ù	167	º	183	⌞	199	⌞	215	⌞	231	τ	247	≈
136	ê	152	ÿ	168	¿	184	⌞	200	⌞	216	⌞	232	Φ	248	°
137	ë	153	Ö	169	┌	185	⌞	201	⌞	217	⌞	233	⊕	249	.
138	è	154	Û	170	└	186	⌞	202	⌞	218	┌	234	Ω	250	.
139	ï	155	¢	171	½	187	⌞	203	⌞	219	■	235	δ	251	√
140	î	156	£	172	¼	188	⌞	204	⌞	220	■	236	∞	252	∞
141	ì	157	¥	173	¡	189	⌞	205	=	221	■	237	φ	253	²
142	Ä	158	€	174	«	190	⌞	206	⌞	222	■	238	ε	254	■
143	Å	159	ƒ	175	»	191	└	207	⌞	223	■	239	∩	255	

Source: www.LookupTables.com

聾	聾	聾	聽	聵	聵	職	瞻
8071	8072	8073	8074	8075	8076	8077	8078
健	腭	腳	腴	暇	暇	膈	腸
8171	8172	8173	8174	8175	8176	8177	8178
艱	色	艷	艷	艷	艷	艷	艸
8271	8272	8273	8274	8275	8276	8277	8278
毫	莖	荳	扶	葱	苳	荷	葶
8371	8372	8373	8374	8375	8376	8377	8378
葱	藁	葳	葳	葵	葶	葶	蔥

Unicode

U+12400	U+12401	U+12402	U+12403	U+12404	U+12405	U+12406	U+12407	U+12408	U+12409	U+1240A	U+1240B	U+1240C	U+1240D	U+1240E	U+1240F
U+12410	U+12411	U+12412	U+12413	U+12414	U+12415	U+12416	U+12417	U+12418	U+12419	U+1241A	U+1241B	U+1241C	U+1241D	U+1241E	U+1241F
U+12420	U+12421	U+12422	U+12423	U+12424	U+12425	U+12426	U+12427	U+12428	U+12429	U+1242A	U+1242B	U+1242C	U+1242D	U+1242E	U+1242F
U+12430	U+12431	U+12432	U+12433	U+12434	U+12435	U+12436	U+12437	U+12438	U+12439	U+1243A	U+1243B	U+1243C	U+1243D	U+1243E	U+1243F
U+12440	U+12441	U+12442	U+12443	U+12444	U+12445	U+12446	U+12447	U+12448	U+12449	U+1244A	U+1244B	U+1244C	U+1244D	U+1244E	U+1244F
U+12450	U+12451	U+12452	U+12453	U+12454	U+12455	U+12456	U+12457	U+12458	U+12459	U+1245A	U+1245B	U+1245C	U+1245D	U+1245E	U+1245F
U+12460	U+12461	U+12462	U+12463	U+12464	U+12465	U+12466	U+12467	U+12468	U+12469	U+1246A	U+1246B	U+1246C	U+1246D	U+1246E	U+1246F
U+12470	U+12471	U+12472	U+12473	U+12474	U+12475	U+12476	U+12477	U+12478	U+12479	U+1247A	U+1247B	U+1247C	U+1247D	U+1247E	U+1247F

Unicode - Numbers in Cuneiform



HEX COLOR CODES

#000000
RED GRN BLU

HEXADECIMAL NUMBERS

EXAMPLES

Red Value:	First 2 Digits	#FF0000	Pure Red
Green Value:	2nd 2 Digits	#6600FF	Purple
Blue Value:	Last 2 Digits	#888888	Light Gray
Range:	0-9 & A - F	#4B78B5	Medium Blue
Higher Values:	Light Colors	#00CD1D	Light Green
Lower Values:	Dark Colors	#FF5500	Orange
		#FFCC00	Yellow

maroon #800000	red #ff0000	orange #ffa500	yellow #ffff00	olive #808000
purple #800080	fuchsia #ff00ff	white #ffffff	lime #00ff00	green #008000
navy #000080	blue #0000ff	aqua #00ffff	teal #008080	
black #000000	silver #c0c0c0	gray #808080		



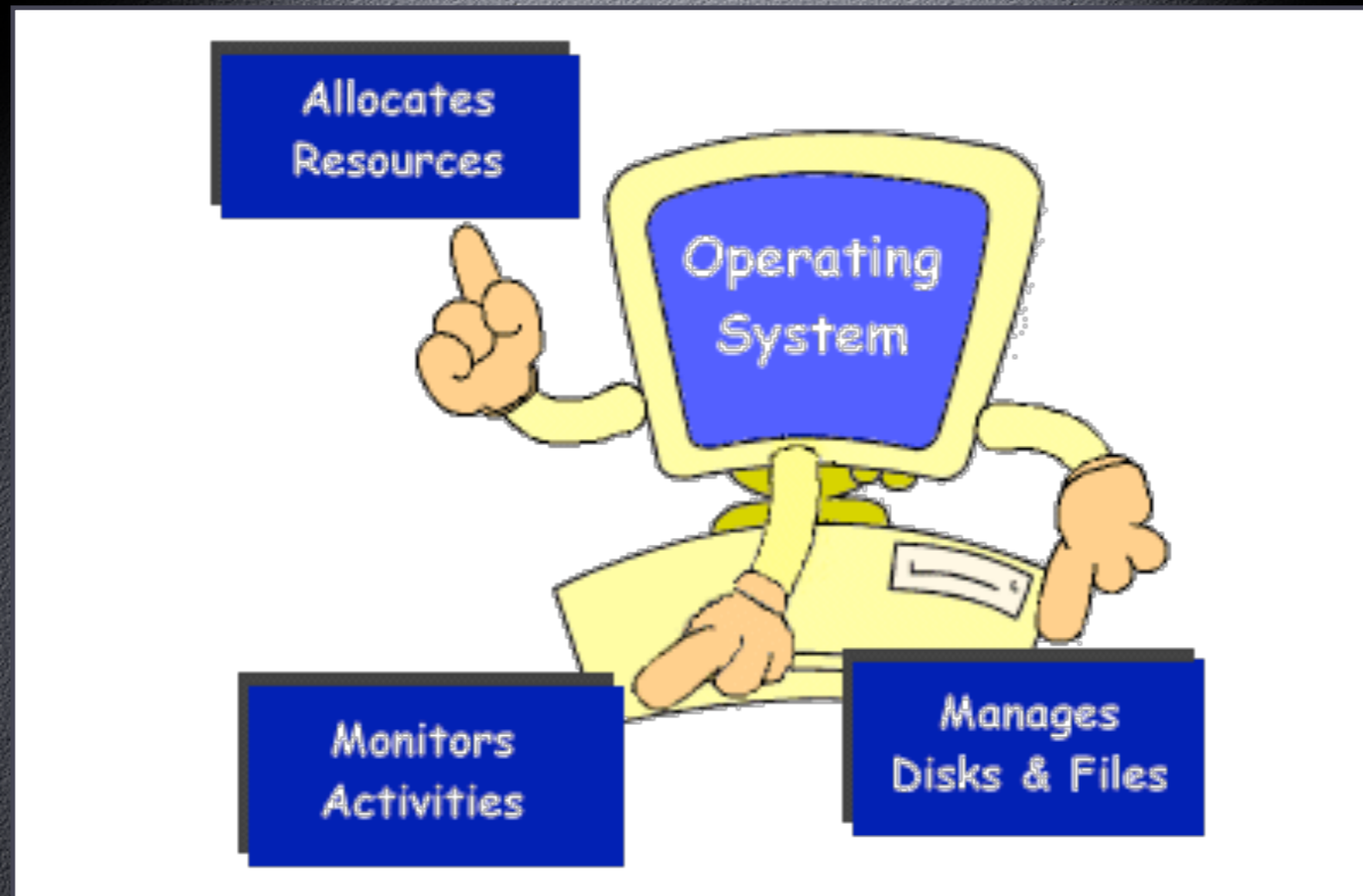

Operating System

